

# Amarillo Series Fan Drive

## Model 65A

Amarillo Gear Company LLC reserves the right to make design modifications to our gear drives that may change the given dimensions. The dimensions shown in this document may not exactly reflect the dimensions of gear drives currently being offered. Request a *certified dimension print* for construction use.

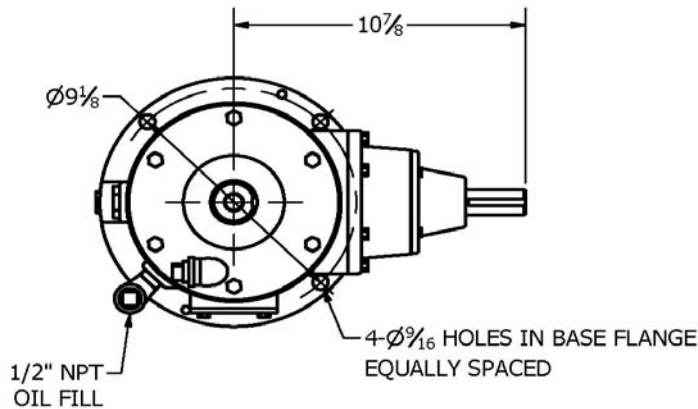

HORIZONTAL KEYWAY: 1/4 X 1/8  
 VERTICAL KEYWAY: 3/8 X 3/16  
 NORMAL ROTATION: BOTH SHAFTS CLOCKWISE

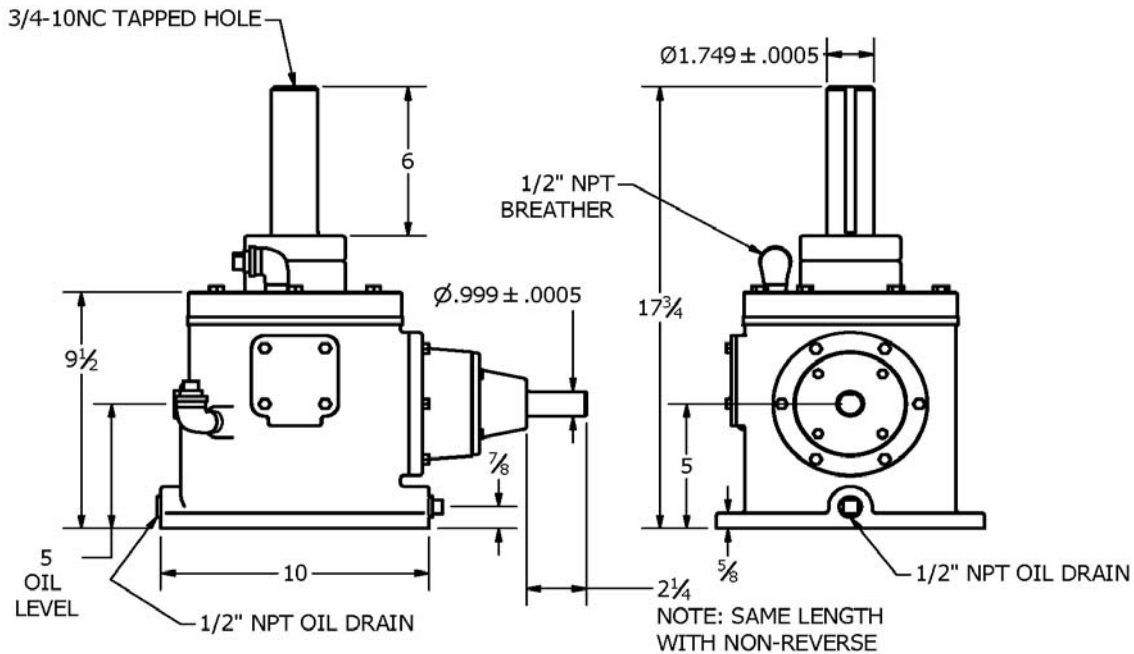

### SERVICE HORSEPOWER RATINGS (2.0 SERVICE FACTOR)

Input (RPM)	Nominal Ratio							
	2.0	2.5	3.0	3.25	3.5	4.0	4.5	5.0
1750	25	25	20	18	17	15	12	10
1450	21	21	17	15	14	12	10	8
1160	17	17	13	12	11	10	8	7

THRUST CAPACITY: \_\_\_\_\_ 1500 lbs.  
 OIL TYPE: \_\_\_\_\_ ISO 220 / AGMA 5 or 5S / No EP additives  
 OIL CAPACITY: \_\_\_\_\_ 0.5 gallons (2 L)  
 WEIGHT, DOMESTIC SHIPPING: \_\_\_\_\_ 100 lbs.  
 WEIGHT, EXPORT SHIPPING w/EXPORT BOX: \_\_\_\_\_ 135 lbs.  
 EXPORT BOX DIMENSIONS (L x W x H): \_\_\_\_\_ 22 x 14 x 21 (inches)