

# Amarillo Series Fan Drive

## Model 1712.5

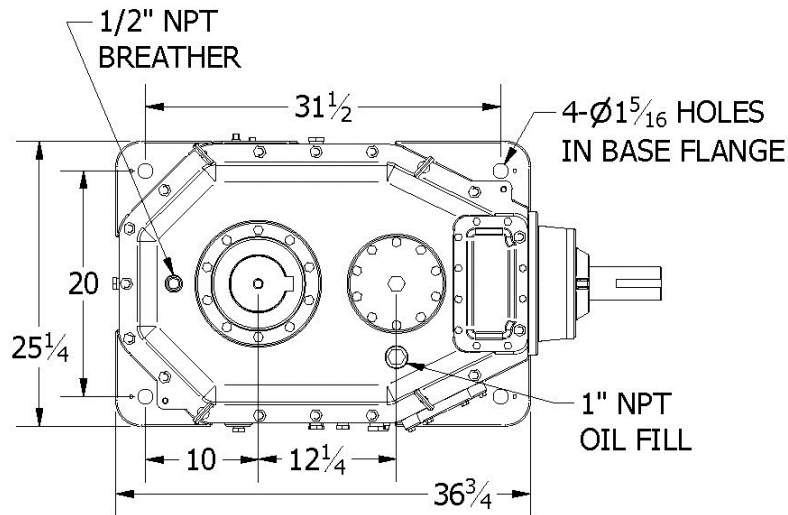

Amarillo Gear Company LLC reserves the right to make design modifications to our gear drives that may change the given dimensions. The dimensions shown in this document may not exactly reflect the dimensions of gear drives currently being offered. Request a *certified dimension print* for construction use.

**OIL PUMP (OPTION) MINIMUM CLEARANCE**  
LOCATED BENEATH THE INTERMEDIATE SHAFT.  
CONTACT THE FACTORY FOR ADDITIONAL  
INFORMATION AND A CERTIFIED DIMENSION PRINT.

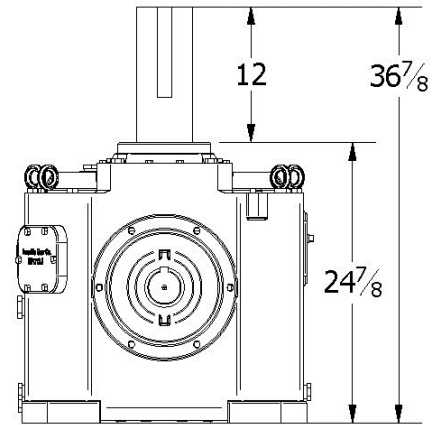
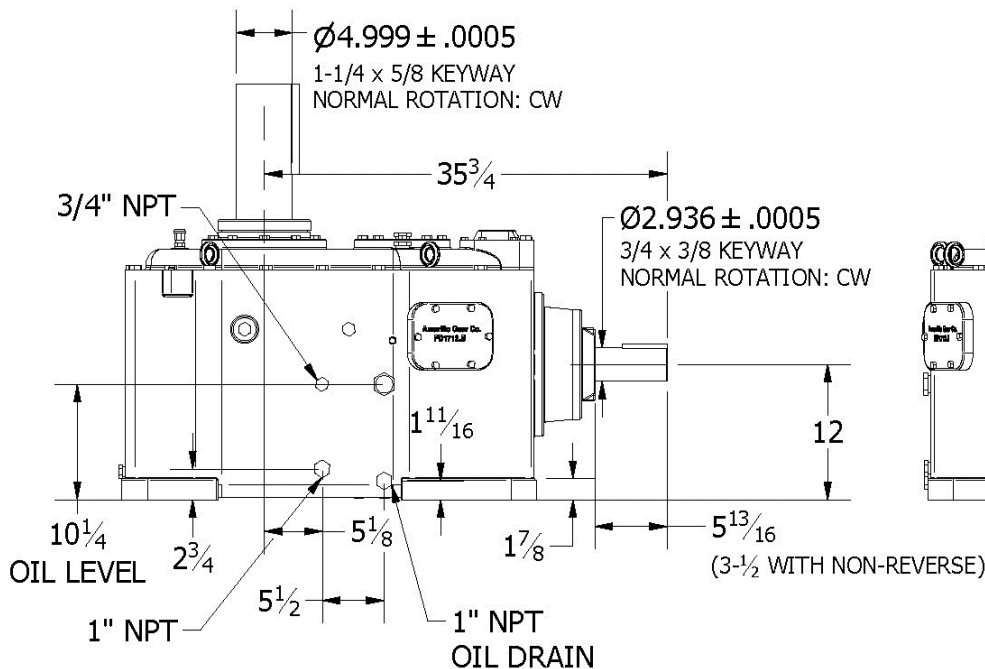
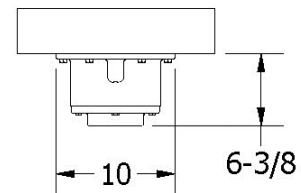

### SERVICE HORSEPOWER RATINGS

(2.0 SERVICE FACTOR)

Input (RPM)	Nominal Ratio										
	11	12	13	14	15	15.5	16	17	18	19	20
1750	309	297	279	262	252	244	236	231	225	201	193
1450	256	246	231	217	209	202	196	191	186	167	160
1160	205	197	185	174	167	162	156	153	149	133	128

THRUST CAPACITY: \_\_\_\_\_ 9250 lbs.  
 OIL TYPE: \_\_\_\_\_ ISO 220 / AGMA 5 or 5S / No EP additives  
 OIL CAPACITY: \_\_\_\_\_ 22 gallons (83 L)  
 WEIGHT, DOMESTIC SHIPPING: \_\_\_\_\_ 2400 lbs.  
 WEIGHT, EXPORT SHIPPING w/EXPORT BOX: \_\_\_\_\_ 2540 lbs.  
 EXPORT BOX DIMENSIONS (L x W x H): \_\_\_\_\_ 50 x 32 x 43 (inches)