

Amarillo Series Fan Drive

Model 135

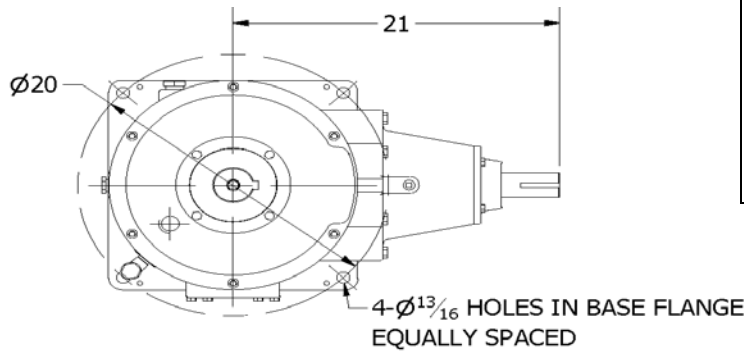

Amarillo Gear Company LLC reserves the right to make design modifications to our gear drives that may change the given dimensions. The dimensions shown in this document may not exactly reflect the dimensions of gear drives currently being offered. Request a *certified dimension print* for construction use.

HORIZONTAL KEYWAY: 3/8 x 3/16
VERTICAL KEYWAY: 5/8 x 5/16
NORMAL ROTATION: BOTH SHAFTS CLOCKWISE

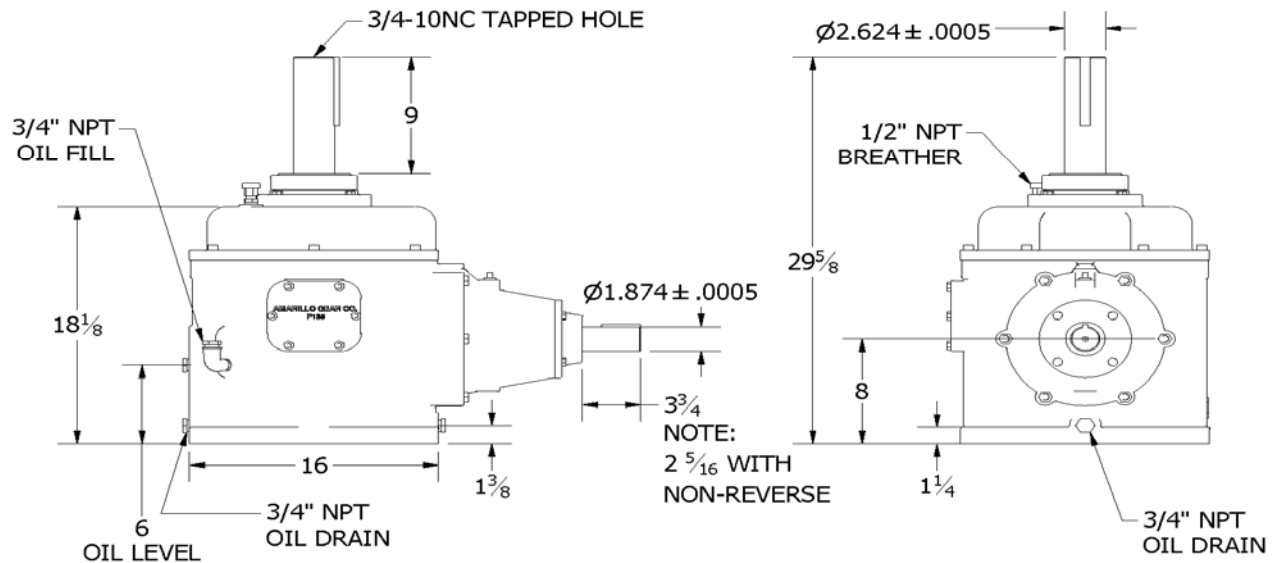

SERVICE HORSEPOWER RATINGS

(2.0 SERVICE FACTOR)

Input (RPM)	Nominal Ratio											
	4.0	4.5	4.75	5.0	5.5	6.0	6.5	7.0	7.5	8.0	8.5	9.0
1750	110	93	88	83	71	65	59	48	43	42	35	30
1450	91	77	73	69	59	54	49	40	36	35	29	25
1160	73	62	58	55	47	43	39	32	29	28	23	20

THRUST CAPACITY: _____ 2500 lbs.
 OIL TYPE: _____ ISO 220 / AGMA 5 or 5S / No EP additives
 OIL CAPACITY: _____ 3 gallons (11 L)
 WEIGHT, DOMESTIC SHIPPING: _____ 530 lbs.
 WEIGHT, EXPORT SHIPPING w/EXPORT BOX: _____ 550 lbs.
 EXPORT BOX DIMENSIONS (L x W x H): _____ 36 x 23 x 34 (inches)